

SNPD1710 Series

USB Type-C Port Controller

1 Introduction

1.1 Features

- Memory configuration
 - 16 KB on-chip flash programming memory
 - 1.25 KB SRAM
- 8-bit 8051 with frequency up to 8 MHz
- On-Chip Debug System (OCDS) interface
- Built-in Watchdog Timer (WDT)
- Interrupt sources including BMC, QC I/O, ADC, OVP, UVP, SCP, OCP, OTP, NDT, T0, and T1
- 5V I/O pin configuration
 - Bi-directional
 - Wakeup I/Os
 - Pull-up resistors
 - 10 mA source and sink current
- High voltage I/O pin configuration
 - Gate driver control I/O for external MOS: VBUS_CTRL
 - Sink currents for discharge and monitor: DISC_MON
 - Cathode I/O for shunt regulator: CATH
- Type-C and USB-PD support
 - USB PD 3.1 Version 1.1 specification including Programmable Power Supply (PPS) mode
 - Configurable resistors R_P and R_D
 - One USB Type-C port and one Type-A port
 - VCONN power and switch for reading E-Marked cable
- Quick Charge™ (QC) protocol
 - Supports one set of QC I/O and integrates all required terminations on DP/DM lines
 - Supports BC1.2, QC 2.0/3.0/4.0/4.0+/5.0
- Shunt regulator
 - Analog regulation of secondary side feedback node (optocoupler)
 - For VBUS control with step 20 mV, 14.6 mV or 10 mV ranging from 3V to 24.5V output
 - Constant current or constant voltage mode
 - Supports low-side current sensing for constant current feedback for the optocoupler
- Operating voltage and temperature
 - 3V to 24.5V operation from VCC
 - Working temperature range: -40°C to 105°C
- Internal 5V regulator output
 - Power input from VCC
 - Driving current 20 mA output with external 1 μ F capacitor
- Low-side Current Sense Amplifier (LSCSA)
 - Programmable gain control: 20, 40, 60, 80, and 100
 - Built-in offset cancellation
- Built-in 12-bit SAR ADC with 4-level internal reference
 - Up to two channels of ADC input
 - Internal reference voltage: 2V, 3V, 4V, and VDD
- Two 8-bit timers: T0 and T1
- 2.6V LVD for VDD
- System clocks
 - Internal high clock: RC type 32 MHz
 - Internal low clock: RC type 16 kHz
- Three operating modes
 - Normal mode: Both high and low clocks are active
 - Idle mode: Wakeup by interrupts
 - Stop mode: Wakeup by I/O, QC I/O, and CC-PHY
- Packages
 - SOP10L
 - SOP14L
 - QFN16L
 - QFN20L

1.2 Description

The SNPD1710 series is a highly integrated USB Type-C port controller that complies with the latest USB Type-C and Power Delivery (PD) standards. With Sonix's proprietary 8051 technology, the SNPD1710 series consists of an 8-bit 8051 processor, a 16 KB on-chip flash programming memory, a complete Type-C USB-PD transceiver, an integrated feedback control circuit for voltage (VBUS) regulation, and all termination resistors required for a Type-C port. Featuring multiple I/Os, well-integrated BOM, and system-level ESD protection, the SNPD1710 series is well-suited for power adapter applications.

1.3 Selection Table

Table 1-1 Selection Table

Device	BMC PHY	QC I/O	Shunt LDO	LSCSA	ADC	Timer	I/O	Package	Tape & Reel Packing
SNPD1711CSG	✓	–	✓	✓	✓	2	0	SOP10L	–
SNPD17111CSG	✓	–	✓	✓	✓	2	0	SOP10L	–
SNPD17112CSG	✓	–	✓	✓	✓	2	0	SOP10L	–
SNPD17113CSG	✓	–	✓	✓	✓	2	0	SOP10L	–
SNPD17114CSG	✓	–	✓	✓	✓	2	0	SOP10L	–
SNPD17116CSG	✓	–	✓	✓	✓	2	0	SOP10L	–
SNPD1712ESG	✓	✓	✓	✓	✓	2	0	SOP14L	–
SNPD17121ESG	✓	✓	✓	✓	✓	2	1	SOP14L	–
SNPD17122ESG	✓	✓	✓	✓	✓	2	0	SOP14L	–
SNPD1713FJG	✓	✓	✓	✓	✓	2	2	QFN16L	–
SNPD1713FJGR ¹	✓	✓	✓	✓	✓	2	2	QFN16L	✓
SNPD17133FJG	✓	✓	✓	✓	✓	2	2	QFN16L	–
SNPD17133FJGR ¹	✓	✓	✓	✓	✓	2	2	QFN16L	✓
SNPD1714HJG	✓	✓	✓	✓	✓	2	4	QFN20L	–
SNPD1714HJGR ¹	✓	✓	✓	✓	✓	2	4	QFN20L	✓

1.4 Functional Block Diagram

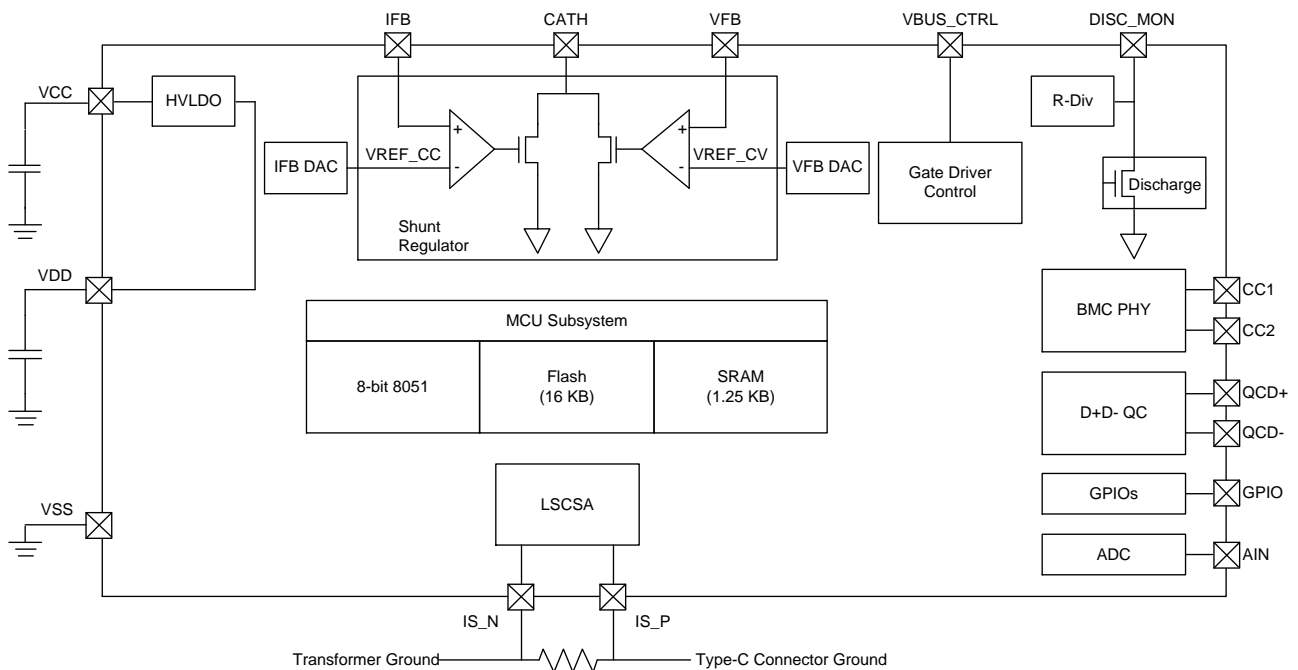

Figure 1-1 Functional Block Diagram

¹ The suffix "R" does not appear on the marking. It is for procurement purpose only.

Revision History

Date	Revision	Description
14-Apr-2022	1.0	Initial release
06-Jul-2022	1.1	Added SNPD17116CSG and related information in Selection Table, Pin Assignment, and Pin Description
24-Oct-2022	1.2	Updated Features \ Type-C and USB-PD support Updated Table 5–4 Updated Package Dimensions \ SOP10L and SOP14L
15-Dec-2022	1.3	Added SNPD17121ESG, SNPD17122ESG, SNPD17131FJG, and SNPD17132FJG and related information in Selection Table, Pin Assignment, and Pin Description
06-Mar-2023	1.4	Added SNPD1713FJGR and SNPD1714HJGR and related information in Selection Table, Table 6–1, and Table 6–2 Removed SNPD17131FJG and SNPD17132FJG and all related information Updated for clarifications
11-Apr-2023	1.5	Added SNPD17133FJG and SNPD17133FJGR and related information in Selection Table, Pin Assignment, and Pin Description

Convention

ⓘ WARNING	Indicates a hazard with a medium or low level of risk that, if not avoided, could result in minor or moderate injury.
✂ TIP	Indicates a tip that may help you solve a problem or save time.
📖 NOTE	Provides additional information to emphasize or supplement important points of the main text.

Table of Contents

1	Introduction	1
1.1	Features	1
1.2	Description	1
1.3	Selection Table.....	2
1.4	Functional Block Diagram	2
2	Pin Information	7
2.1	SNPD1711CSG.....	7
2.1.1	Pin Assignment	7
2.1.2	Pin Description	7
2.2	SNPD17111CSG.....	8
2.2.1	Pin Assignment	8
2.2.2	Pin Description	8
2.3	SNPD17112CSG.....	9
2.3.1	Pin Assignment	9
2.3.2	Pin Description	9
2.4	SNPD17113CSG.....	10
2.4.1	Pin Assignment	10
2.4.2	Pin Description	10
2.5	SNPD17114CSG.....	11
2.5.1	Pin Assignment	11
2.5.2	Pin Description	11
2.6	SNPD17116CSG.....	12
2.6.1	Pin Assignment	12
2.6.2	Pin Description	12
2.7	SNPD1712ESG.....	13
2.7.1	Pin Assignment	13
2.7.2	Pin Description	13
2.8	SNPD17121ESG.....	14
2.8.1	Pin Assignment	14
2.8.2	Pin Description	14
2.9	SNPD17122ESG.....	15
2.9.1	Pin Assignment	15
2.9.2	Pin Description	15
2.10	SNPD1713FJG.....	16
2.10.1	Pin Assignment	16
2.10.2	Pin Description	17
2.11	SNPD17133FJG.....	18
2.11.1	Pin Assignment	18
2.11.2	Pin Description	19
2.12	SNPD1714HJG	20
2.12.1	Pin Assignment	20
2.12.2	Pin Description	21
3	System	22
3.1	MCU Subsystem	22
3.2	USB-PD Subsystem	22
3.2.1	USB-PD Physical Layer	22
3.2.2	ADC.....	22
3.2.3	Charger Detection (QCD+/QCD-).....	22
3.2.4	VBUS Overcurrent and Overvoltage Protection	22
3.2.5	Low-side Current Sense Amplifier (LSCSA).....	23
3.2.6	MOSFET of Gate Driver on VBUS Path	23
3.2.7	VBUS Discharger FETs.....	23

3.2.8	Shunt Regulator	23
3.3	Power System	23
4	Application – Power Adapter	24
5	Device Operating Conditions	26
5.1	Absolute Maximum Ratings	26
5.2	Recommended Operating Conditions	26
5.3	AC Characteristics	29
6	Mechanical Data	30
6.1	Thermal Data	30
6.2	Package Information	30
6.2.1	Nomenclature	30
6.2.2	Marking	31
6.2.3	Package Dimensions	32
6.3	Packing Appearance and Storage Information	36
6.3.1	Packing Quantity Information	36
6.3.2	Packing Box/Carton Dimension	36
6.3.3	Temperature and Humidity Environmental Control Requirements in Storage	36
6.3.4	Shelf-life	36

List of Figures

Figure 1–1	Functional Block Diagram	2
Figure 2–1	SNPD1711CSG Pin Assignment	7
Figure 2–2	SNPD17111CSG Pin Assignment	8
Figure 2–3	SNPD17112CSG Pin Assignment	9
Figure 2–4	SNPD17113CSG Pin Assignment	10
Figure 2–5	SNPD17114CSG Pin Assignment	11
Figure 2–6	SNPD17116CSG Pin Assignment	12
Figure 2–7	SNPD1712ESG Pin Assignment	13
Figure 2–8	SNPD17121ESG Pin Assignment	14
Figure 2–9	SNPD17122ESG Pin Assignment	15
Figure 2–10	SNPD1713FJG Pin Assignment	16
Figure 2–11	SNPD17133FJG Pin Assignment	18
Figure 2–12	SNPD1714HJG Pin Assignment	20
Figure 4–1	Power Adapter Application with PMOS Control	24
Figure 4–2	Power Adapter Application with NMOS Control	25
Figure 6–1	Device Nomenclature	30
Figure 6–2	Example of Device Marking	31

List of Tables

Table 1–1	Selection Table	2
Table 2–1	SNPD1711CSG Pin Description	7
Table 2–2	SNPD17111CSG Pin Description	8
Table 2–3	SNPD17112CSG Pin Description	9
Table 2–4	SNPD17113CSG Pin Description	10
Table 2–5	SNPD17114CSG Pin Description	11
Table 2–6	SNPD17116CSG Pin Description	12
Table 2–7	SNPD1712ESG Pin Description	13
Table 2–8	SNPD17121ESG Pin Description	14
Table 2–9	SNPD17122ESG Pin Description	15
Table 2–10	SNPD1713FJG Pin Description	17
Table 2–11	SNPD17133FJG Pin Description	19
Table 2–12	SNPD1714HJG Pin Description	21
Table 3–1	Power Mode	23
Table 5–1	Absolute Maximum Ratings	26
Table 5–2	Recommended Operating Conditions	26
Table 5–3	Electrical Characteristics for DC Specifications	26
Table 5–4	Electrical Characteristics for I/O DC Specifications	27
Table 5–5	Electrical Characteristics for ADC DC Specifications	27
Table 5–6	Electrical Characteristics for Current Sense Amplifier	27
Table 5–7	Electrical Characteristics for DISC_MON	28
Table 5–8	Electrical Characteristics for VCC_DISC	28
Table 5–9	Electrical Characteristics for QCD+/QCD- Specifications	28
Table 5–10	Electrical Characteristics for CC1/CC2 Specifications	28
Table 5–11	Electrical Characteristics for Shunt Regulator Specifications	28
Table 5–12	Electrical Characteristics for Gate Driver Specifications	29
Table 5–13	AC Specifications	29
Table 6–1	Packing Quantity Information	36
Table 6–2	Inner Box/Carton Dimension	36
Table 6–3	Store Condition	36

2 Pin Information

2.1 SNPD1711CSG

2.1.1 Pin Assignment

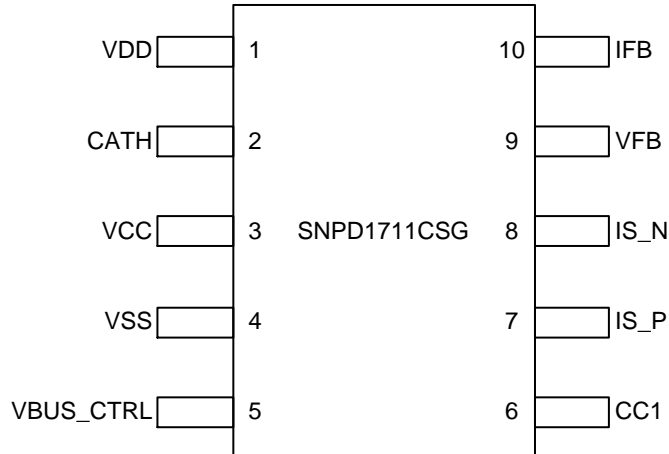

Figure 2-1 SNPD1711CSG Pin Assignment

2.1.2 Pin Description

Table 2-1 SNPD1711CSG Pin Description

Name	Pin No.	Type ²	Description
VDD	1	P	HV LDO output for digital and analog circuits
CATH	2	AI	Cathode of voltage regulation and compensation for other applications
VCC	3	P	Power supply input voltage
VSS	4	GND	Power supply ground
VBUS_CTRL	5	I/O	External MOSFET control
CC1	6	I/O	Type-C connector configuration channel 1
IS_P	7	AI	Positive input of a current sense amplifier for output current sensing
IS_N	8	AI	Negative input of a current sense amplifier for output current sensing
VFB	9	AI	Feedback input for the constant-voltage loop
IFB	10	AI	Feedback input for the constant-current loop

² Signal Types:
I = Input
O = Output
A = Analog signal
P = Power
GND = Ground

2.2 SNPD17111CSG

2.2.1 Pin Assignment

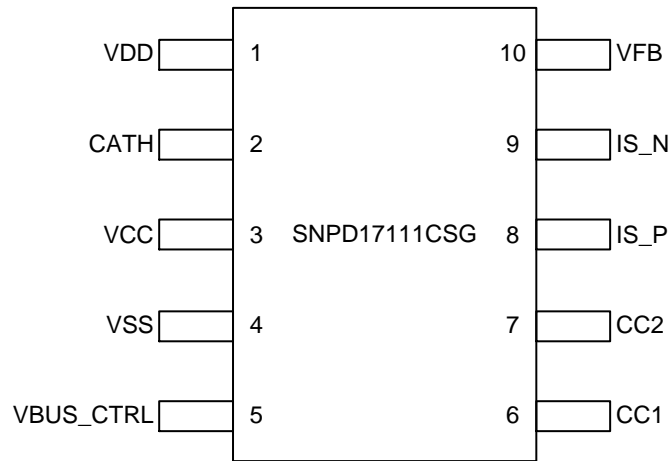

Figure 2–2 SNPD17111CSG Pin Assignment

2.2.2 Pin Description

Table 2–2 SNPD17111CSG Pin Description

Name	Pin No.	Type ³	Description
VDD	1	P	HV LDO output for digital and analog circuits
CATH	2	AI	Cathode of voltage regulation and compensation for other applications
VCC	3	P	Power supply input voltage
VSS	4	GND	Power supply ground
VBUS_CTRL	5	I/O	External MOSFET control
CC1	6	I/O	Type-C connector configuration channel 1
CC2	7	I/O	Type-C connector configuration channel 2
IS_P	8	AI	Positive input of a current sense amplifier for output current sensing
IS_N	9	AI	Negative input of a current sense amplifier for output current sensing
VFB	10	AI	Feedback input for the constant-voltage loop

³ Signal Types:
I = Input
O = Output
A = Analog signal
P = Power
GND = Ground

2.3 SNPD17112CSG

2.3.1 Pin Assignment

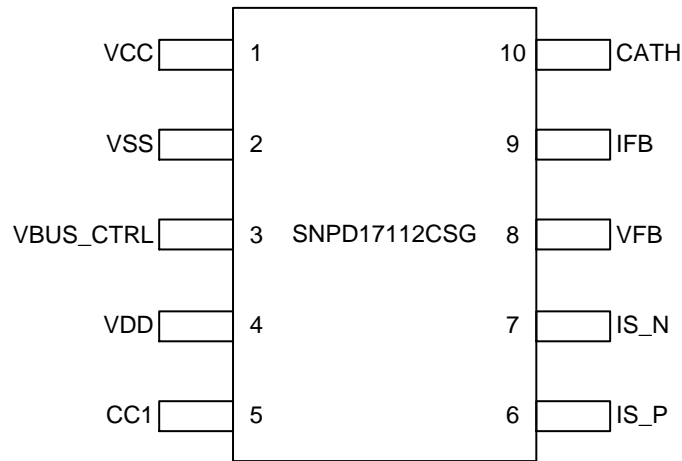

Figure 2–3 SNPD17112CSG Pin Assignment

2.3.2 Pin Description

Table 2–3 SNPD17112CSG Pin Description

Name	Pin No.	Type ⁴	Description
VCC	1	P	Power supply input voltage
VSS	2	GND	Power supply ground
VBUS_CTRL	3	I/O	External MOSFET control
VDD	4	P	HV LDO output for digital and analog circuits
CC1	5	I/O	Type-C connector configuration channel 1
IS_P	6	AI	Positive input of a current sense amplifier for output current sensing
IS_N	7	AI	Negative input of a current sense amplifier for output current sensing
VFB	8	AI	Feedback input for the constant-voltage loop
IFB	9	AI	Feedback input for the constant-current loop
CATH	10	AI	Cathode of voltage regulation and compensation for other applications

⁴ Signal Types:
I = Input
O = Output
A = Analog signal
P = Power
GND = Ground

2.4 SNPD17113CSG

2.4.1 Pin Assignment

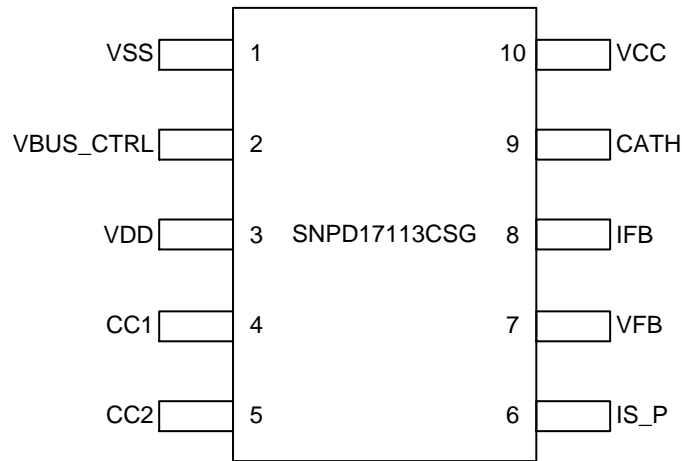

Figure 2–4 SNPD17113CSG Pin Assignment

2.4.2 Pin Description

Table 2–4 SNPD17113CSG Pin Description

Name	Pin No.	Type ⁵	Description
VSS	1	GND	Power supply ground
VBUS_CTRL	2	I/O	External MOSFET control
VDD	3	P	HV LDO output for digital and analog circuits
CC1	4	I/O	Type-C connector configuration channel 1
CC2	5	I/O	Type-C connector configuration channel 2
IS_P	6	AI	Positive input of a current sense amplifier for output current sensing
VFB	7	AI	Feedback input for the constant-voltage loop
IFB	8	AI	Feedback input for the constant-current loop
CATH	9	AI	Cathode of voltage regulation and compensation for other applications
VCC	10	P	Power supply input voltage

⁵ Signal Types:
I = Input
O = Output
A = Analog signal
P = Power
GND = Ground

2.5 SNPD17114CSG

2.5.1 Pin Assignment

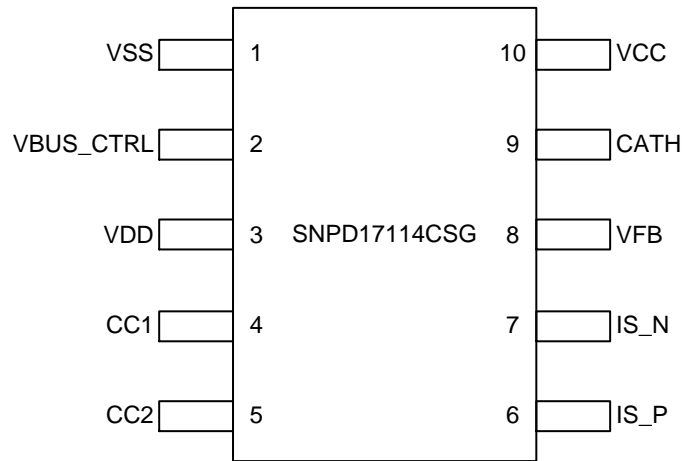

Figure 2-5 SNPD17114CSG Pin Assignment

2.5.2 Pin Description

Table 2-5 SNPD17114CSG Pin Description

Name	Pin No.	Type ⁶	Description
VSS	1	GND	Power supply ground
VBUS_CTRL	2	I/O	External MOSFET control
VDD	3	P	HV LDO output for digital and analog circuits
CC1	4	I/O	Type-C connector configuration channel 1
CC2	5	I/O	Type-C connector configuration channel 2
IS_P	6	AI	Positive input of a current sense amplifier for output current sensing
IS_N	7	AI	Negative input of a current sense amplifier for output current sensing
VFB	8	AI	Feedback input for the constant-voltage loop
CATH	9	AI	Cathode of voltage regulation and compensation for other applications
VCC	10	P	Power supply input voltage

⁶ Signal Types:
I = Input
O = Output
A = Analog signal
P = Power
GND = Ground

2.6 SNPD17116CSG

2.6.1 Pin Assignment

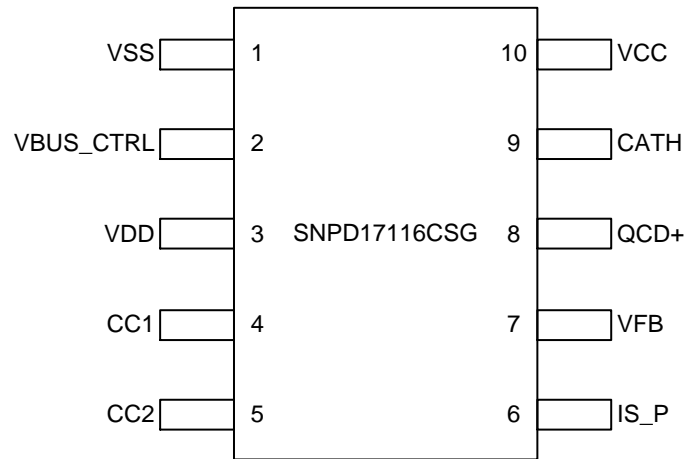

Figure 2–6 SNPD17116CSG Pin Assignment

2.6.2 Pin Description

Table 2–6 SNPD17116CSG Pin Description

Name	Pin No.	Type ⁷	Description
VSS	1	GND	Power supply ground
VBUS_CTRL	2	I/O	External MOSFET control
VDD	3	P	HV LDO output for digital and analog circuits
CC1	4	I/O	Type-C connector configuration channel 1
CC2	5	I/O	Type-C connector configuration channel 2
IS_P	6	AI	Positive input of a current sense amplifier for output current sensing
VFB	7	AI	Feedback input for the constant-voltage loop
QCD+	8	I/O	USB D+ channel
CATH	9	AI	Cathode of voltage regulation and compensation for other applications
VCC	10	P	Power supply input voltage

⁷ Signal Types:
I = Input
O = Output
A = Analog signal
P = Power
GND = Ground

2.7 SNPD1712ESG

2.7.1 Pin Assignment

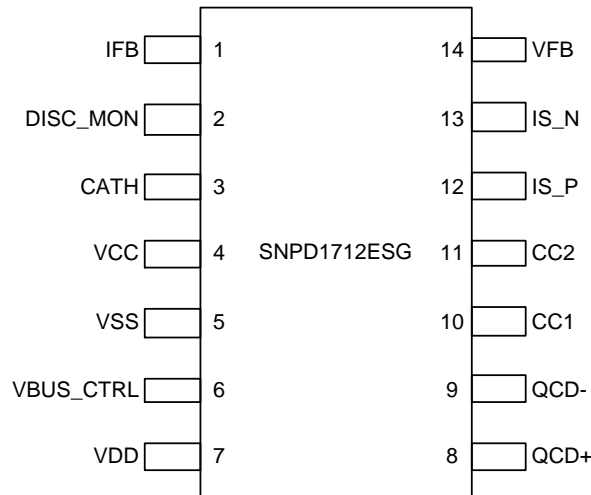

Figure 2-7 SNPD1712ESG Pin Assignment

2.7.2 Pin Description

Table 2-7 SNPD1712ESG Pin Description

Name	Pin No.	Type ⁸	Description
IFB	1	AI	Feedback input for the constant-current loop
DISC_MON	2	AO	Type-C VBUS monitor with internal discharge FET
CATH	3	AI	Cathode of voltage regulation and compensation for other applications
VCC	4	P	Power supply input voltage
VSS	5	GND	Power supply ground
VBUS_CTRL	6	I/O	External MOSFET control
VDD	7	P	HV LDO output for digital and analog circuits
QCD+	8	I/O	USB D+ channel
QCD-	9	I/O	USB D- channel
CC1	10	I/O	Type-C connector configuration channel 1
CC2	11	I/O	Type-C connector configuration channel 2
IS_P	12	AI	Positive input of a current sense amplifier for output current sensing
IS_N	13	AI	Negative input of a current sense amplifier for output current sensing
VFB	14	AI	Feedback input for the constant-voltage loop

⁸ Signal Types:
I = Input
O = Output
A = Analog signal
P = Power
GND = Ground

2.8 SNPD17121ESG

2.8.1 Pin Assignment

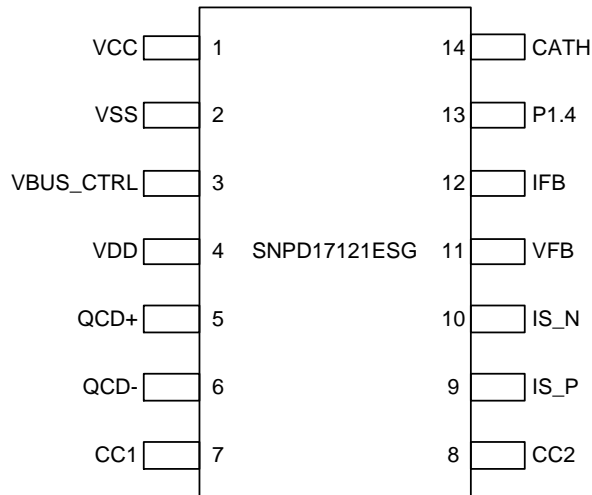

Figure 2-8 SNPD17121ESG Pin Assignment

2.8.2 Pin Description

Table 2-8 SNPD17121ESG Pin Description

Name	Pin No.	Type ⁹	Description
VCC	1	P	Power supply input voltage
VSS	2	GND	Power supply ground
VBUS_CTRL	3	I/O	External MOSFET control
VDD	4	P	HV LDO output for digital and analog circuits
QCD+	5	I/O	USB D+ channel
QCD-	6	I/O	USB D- channel
CC1	7	I/O	Type-C connector configuration channel 1
CC2	8	I/O	Type-C connector configuration channel 2
IS_P	9	AI	Positive input of a current sense amplifier for output current sensing
IS_N	10	AI	Negative input of a current sense amplifier for output current sensing
VFB	11	AI	Feedback input for the constant-voltage loop
IFB	12	AI	Feedback input for the constant-current loop
P1.4	13	I/O	General purpose digital input/output
CATH	14	AI	Cathode of voltage regulation and compensation for other applications

⁹ Signal Types:
I = Input
O = Output
A = Analog signal
P = Power
GND = Ground

2.9 SNPD17122ESG

2.9.1 Pin Assignment

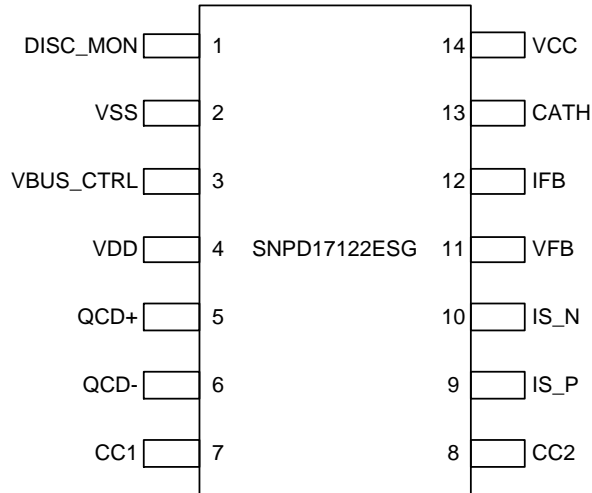

Figure 2-9 SNPD17122ESG Pin Assignment

2.9.2 Pin Description

Table 2-9 SNPD17122ESG Pin Description

Name	Pin No.	Type ¹⁰	Description
DISC_MON	1	AO	Type-C VBUS monitor with internal discharge FET
VSS	2	GND	Power supply ground
VBUS_CTRL	3	I/O	External MOSFET control
VDD	4	P	HV LDO output for digital and analog circuits
QCD+	5	I/O	USB D+ channel
QCD-	6	I/O	USB D- channel
CC1	7	I/O	Type-C connector configuration channel 1
CC2	8	I/O	Type-C connector configuration channel 2
IS_P	9	AI	Positive input of a current sense amplifier for output current sensing
IS_N	10	AI	Negative input of a current sense amplifier for output current sensing
VFB	11	AI	Feedback input for the constant-voltage loop
IFB	12	AI	Feedback input for the constant-current loop
CATH	13	AI	Cathode of voltage regulation and compensation for other applications
VCC	14	P	Power supply input voltage

¹⁰ Signal Types:
I = Input
O = Output
A = Analog signal
P = Power
GND = Ground

2.10 SNPD1713FJG

2.10.1 Pin Assignment

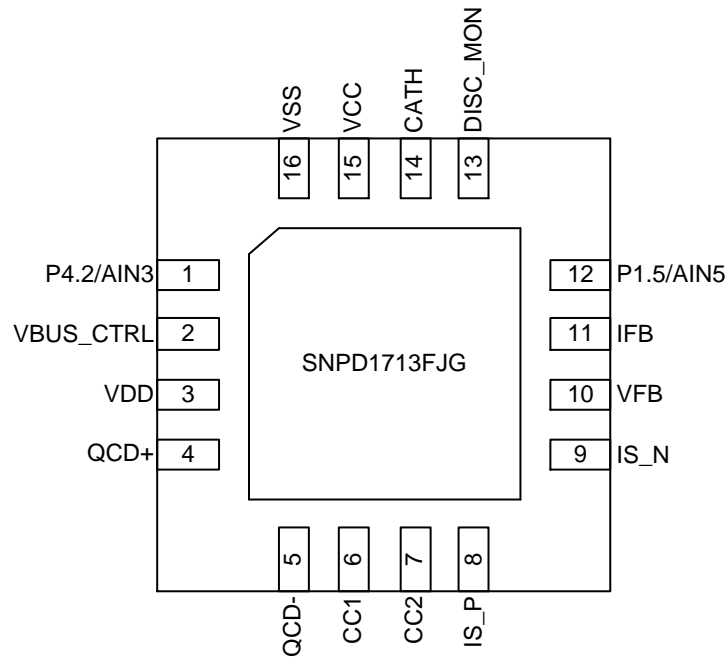

Figure 2-10 SNPD1713FJG Pin Assignment

2.10.2 Pin Description

Table 2–10 SNPD1713FJG Pin Description

Name	Pin No.	Type ¹¹	Description
P4.2	1	I/O	General purpose digital input/output
AIN3		AI	ADC input channel 3
VBUS_CTRL	2	I/O	External MOSFET control
VDD	3	P	HV LDO output for digital and analog circuits
QCD+	4	I/O	USB D+ channel
QCD-	5	I/O	USB D- channel
CC1	6	I/O	Type-C connector configuration channel 1
CC2	7	I/O	Type-C connector configuration channel 2
IS_P	8	AI	Positive input of a current sense amplifier for output current sensing
IS_N	9	AI	Negative input of a current sense amplifier for output current sensing
VFB	10	AI	Feedback input for the constant-voltage loop
IFB	11	AI	Feedback input for the constant-current loop
P1.5	12	I/O	General purpose digital input/output
AIN5		AI	ADC input channel 5
DISC_MON	13	AO	Type-C VBUS monitor with internal discharge FET
CATH	14	AI	Cathode of voltage regulation and compensation for other applications
VCC	15	P	Power supply input voltage
VSS	16	GND	Power supply ground

¹¹ Signal Types:
I = Input
O = Output
A = Analog signal
P = Power
GND = Ground

2.11 SNPD17133FJG

2.11.1 Pin Assignment

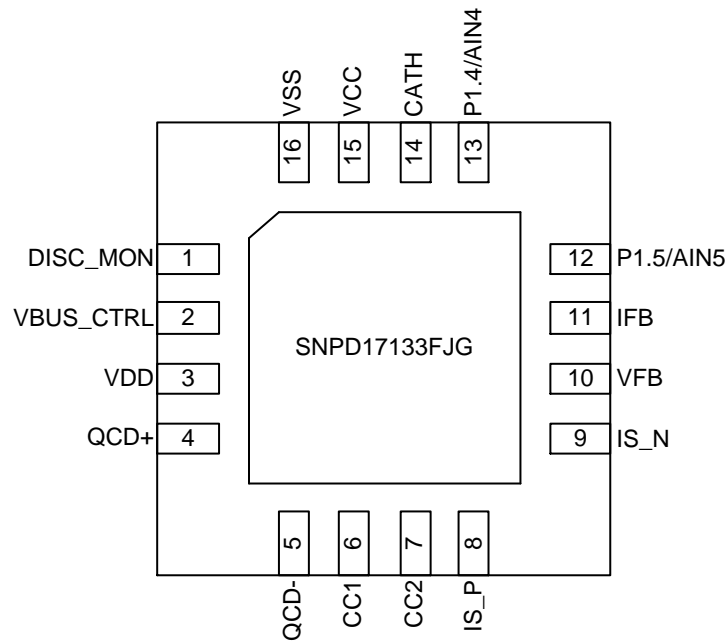

Figure 2-11 SNPD17133FJG Pin Assignment

2.11.2 Pin Description

Table 2-11 SNPD17133FJG Pin Description

Name	Pin No.	Type ¹²	Description
DISC_MON	1	AO	Type-C VBUS monitor with internal discharge FET
VBUS_CTRL	2	I/O	External MOSFET control
VDD	3	P	HV LDO output for digital and analog circuits
QCD+	4	I/O	USB D+ channel
QCD-	5	I/O	USB D- channel
CC1	6	I/O	Type-C connector configuration channel 1
CC2	7	I/O	Type-C connector configuration channel 2
IS_P	8	AI	Positive input of a current sense amplifier for output current sensing
IS_N	9	AI	Negative input of a current sense amplifier for output current sensing
VFB	10	AI	Feedback input for the constant-voltage loop
IFB	11	AI	Feedback input for the constant-current loop
P1.5	12	I/O	General purpose digital input/output
AIN5		AI	ADC input channel 5
P1.4	13	I/O	General purpose digital input/output
AIN4		AI	ADC input channel 4
CATH	14	AI	Cathode of voltage regulation and compensation for other applications
VCC	15	P	Power supply input voltage
VSS	16	GND	Power supply ground

¹² Signal Types:
I = Input
O = Output
A = Analog signal
P = Power
GND = Ground

2.12 SNPD1714HJG

2.12.1 Pin Assignment

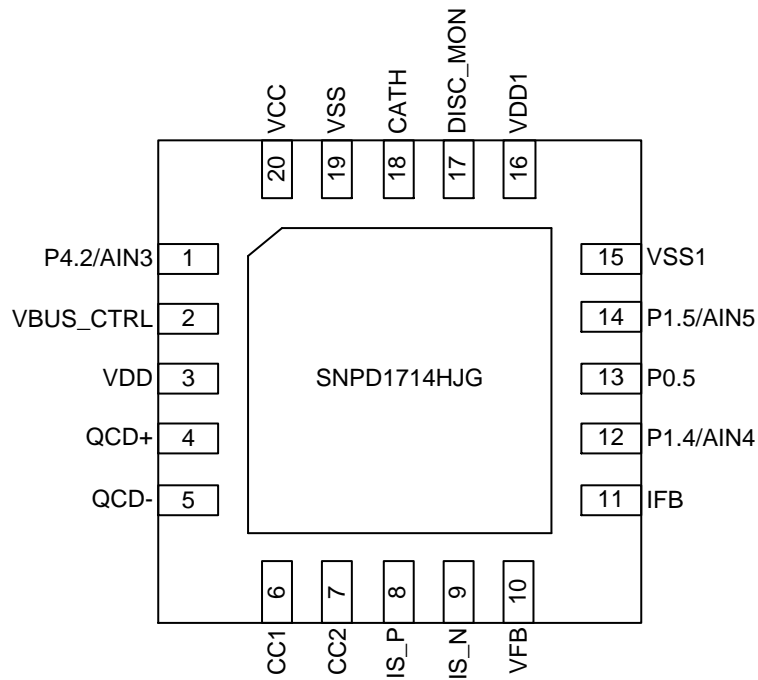

Figure 2-12 SNPD1714HJG Pin Assignment

2.12.2 Pin Description

Table 2–12 SNPD1714HJG Pin Description

Name	Pin No.	Type ¹³	Description
P4.2	1	I/O	General purpose digital input/output
AIN3		AI	ADC input channel 3
VBUS_CTRL	2	I/O	External MOSFET control
VDD	3	P	HV LDO output for digital and analog circuits
QCD+	4	I/O	USB D+ channel
QCD-	5	I/O	USB D- channel
CC1	6	I/O	Type-C connector configuration channel 1
CC2	7	I/O	Type-C connector configuration channel 2
IS_P	8	AI	Positive input of a current sense amplifier for output current sensing
IS_N	9	AI	Negative input of a current sense amplifier for output current sensing
VFB	10	AI	Feedback input for the constant-voltage loop
IFB	11	AI	Feedback input for the constant-current loop
P1.4	12	I/O	General purpose digital input/output
AIN4		AI	ADC input channel 4
P0.5	13	I/O	General purpose digital input/output
P1.5	14	I/O	General purpose digital input/output
AIN5		AI	ADC input channel 5
VSS1	15	GND	Power supply ground
VDD1	16	P	HV LDO output for digital and analog circuits
DISC_MON	17	AO	Type-C VBUS monitor with internal discharge FET
CATH	18	AI	Cathode of voltage regulation and compensation for other applications
VSS	19	GND	Power supply ground
VCC	20	P	Power supply input voltage

¹³ Signal Types:
I = Input
O = Output
A = Analog signal
P = Power
GND = Ground

3 System

- 3.1 MCU Subsystem
- 3.2 USB-PD Subsystem
- 3.3 Power System

3.1 MCU Subsystem

The SNPD1710 series has a MCU subsystem, which integrates an 8-bit 8051 processor. The MCU subsystem includes a 16 KB flash ROM, a 1.25 KB SRAM, and two 8-bit timers consisting of 32 MHz RC oscillators and 16 kHz RC oscillators to achieve high efficiency with low power consumption.

3.2 USB-PD Subsystem

3.2.1 USB-PD Physical Layer

The USB-PD physical layer consists of a transmitter and a receiver that communicate BMC-encoded data over the configuration channel (CC) based on the PD 3.1 standard. All communication is half-duplex. The physical layer or PHY provides collision avoidance to minimize communication errors on the channel.

The USB-PD block includes all termination resistors (R_P and R_D) and their switches as required by the USB-PD specification. R_P and R_D resistors are required to implement connection detection, plug orientation detection, and for establishing USB DFP/UFP roles. The R_P resistor is implemented as a current source.

According to the USB Type-C specification, a Type-C controller such as the SNPD1710 series must present certain termination resistors depending on its role in its unpowered state. The sink role in a power bank application requires R_D resistors to be present on the CC pins whereas the DFP role, as in a power adapter, requires both CC pins to be open. To be flexible for such applications, the SNPD1710 series includes the resistors required in the unpowered state on separate pads or pins.

3.2.2 ADC

The high precision 12-bit SAR ADC is used to detect and monitor analog signals of the peripherals such as the signals of the voltage detection circuit at CC1/CC2 and QCD+/QCD-, output voltage and current of VBUS, and internal thermal sensor and signals for external NTC thermal detection.

3.2.3 Charger Detection (QCD+/QCD-)¹⁴

The D+/D- detection and charging protocol are compliant with conventional battery charging protocol (BC1.2) and Qualcomm Quick Charge 2.0/3.0/4.0/4.0+/5.0 charging protocols.

3.2.4 VBUS Overcurrent and Overvoltage Protection

The VBUS voltage sensing circuit and the shunt regulator of the SNPD1710 series form an integrated hardware protection circuit with fast response and adjustability for VBUS overvoltage and overcurrent protection.

¹⁴ Only available with SNPD1712ESG, SNPD17121ESG, SNPD17122ESG, SNPD1713FJG, SNPD17133FJG, and SNPD1714HJG.

3.2.5 Low-side Current Sense Amplifier (LSCSA)

The SNPD1710 series has a built-in current sensing circuit with input offset cancellation and programmable gain selections including 20, 40, 60, 80 and 100 V/V. With an external 5 mΩ precision resistor, the accuracy of the sensing circuit is 50 mA. The LSCSA also supports constant current mode in a power adapter application as a source.

3.2.6 MOSFET of Gate Driver on VBUS Path

A built-in gate driver controls the external MOS switch on the VBUS. The MOS switch is turned on when the Type-C sink side is attached. The MOS switch is turned off when the Type-C sink side is detached or an error (i.e. overcurrent, short circuit...) occurs.

3.2.7 VBUS Discharger FETs

The VBUS discharge circuit of the SNPD1710 series discharges secondary-side bulk capacitor voltage when a device is removed or during voltage decrease (i.e. from 20V to 12V) to achieve the time requirement of the USB-PD specification. The typical value of the sink current is 16 mA.

3.2.8 Shunt Regulator

Two regulators are parallel and connected to an open-drain output, CATH pin. The operation of each feedback loop is similar to that of a typical TL431 shunt regulator except that VCATH operating range is wider, from -0.3V to VCC + 0.3V, which enables simple designs of the converters with a wider output range.

The VFB DAC and IFB DAC convert the signals from the MCU subsystem to reference voltage and current (VREF_CV and VREF_CC) for the voltage and current feedback loops (VFB and IFB) respectively. The analog output range of the 11-bit DAC is from 0 to VDAC_MAX (typically 3V), which makes output voltage resolution as small as 10 mV, 14.6 mV, or 20 mV to achieve high-precision CV regulation.

3.3 Power System

The SNPD1710 series can operate from single external supply source, VCC (3.0V to 24.5V). When powered through VCC, the internal regulator generates a VDD of 5V for chip operation. The regulated supply is used directly inside some analog blocks. The SNPD1710 series has three different power modes: normal, idle, and stop. The POR (Power-on Reset) status is when power is valid and an internal reset source is asserted or the sleep controller is sequencing the system out of reset.

Transitions between these power modes are managed by the power system. When powered through the VCC pin, the VDD cannot be used to power external devices and should be connected to a 1 μF capacitor for regulator stability. These pins are not supported as power supplies. Figure 4–1 and Figure 4–2 show the application diagrams for capacitor connections.

Table 3–1 Power Mode

Name	Description
Normal Mode	Power is valid and the CPU is executing instructions.
Idle Mode	Power is valid and the CPU is not executing instructions. All logic that is not operating is clock gated to save power.
Stop Mode	The main regulator and most blocks are shut off. The stop regulator powers logic, but only the low-frequency clock is available.

4 Application – Power Adapter

The SNPD1710 series controls the power supply to the device according to the response of the device from the handshake when the power adapter, the device, and the AC power supply are connected. In the power converter application, the shunt regulator of the SNPD1710 series forms a feedback path with an optocoupler. The feedback voltage from the VCC divider voltage and the CATH signal are combined and transmitted to the voltage comparator of the shunt regulator through VFB to compare with VREF_CV from VFB DAC. The feedback current, IS_N and IS_P, from the low side current sense amplifier and the CATH signal are combined and transmitted to the voltage comparator of the shunt regulator through IFB to compare with VREF_CC from IFB DAC. The shunt regulator connects to CATH with optocoupler to feedback signals to the primary-side that has a converter, and to regulate the output voltage and current from the secondary-side where a device is connected depending on the feedback signals. When the power is supplied through VBUS, the SNPD1710 series precisely charges various devices using the USB-PD or the QC protocol. Figure 4-1 and Figure 4-2 illustrate power adapter application with PMOS and NMOS control respectively.

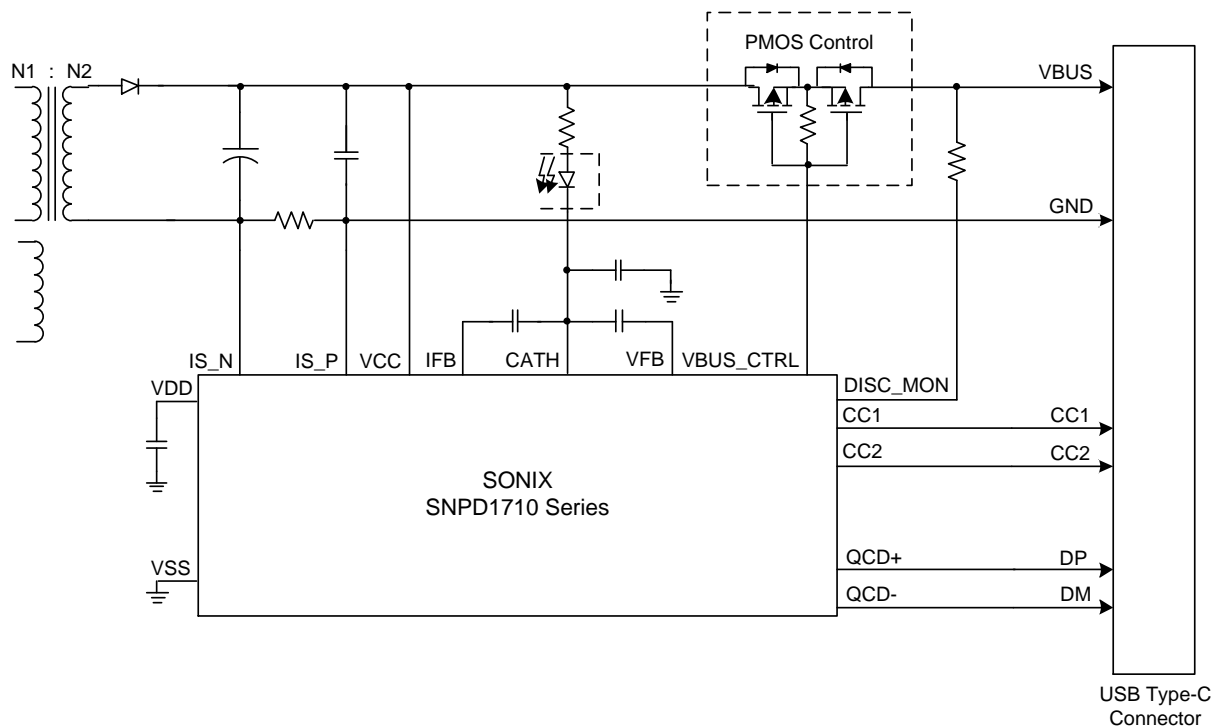

Figure 4-1 Power Adapter Application with PMOS Control

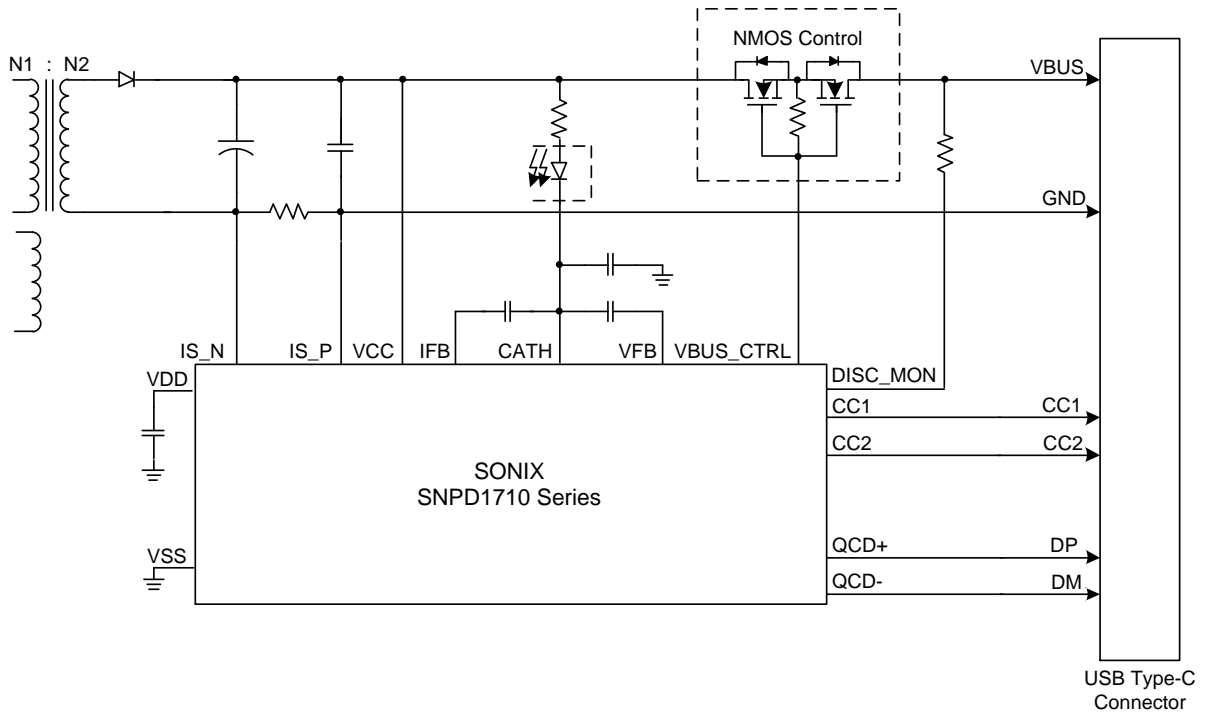

Figure 4-2 Power Adapter Application with NMOS Control

5 Device Operating Conditions

- 5.1 Absolute Maximum Ratings
- 5.2 Recommended Operating Conditions
- 5.3 AC Characteristics

5.1 Absolute Maximum Ratings

Table 5-1 Absolute Maximum Ratings^{15 16 17}

Parameter	Rating	Unit
Supply Voltage Ranges	VCC	-0.3 to 30
Input Voltage Ranges	CC1, CC2, QCD+, QCD-, VBUS_CTRL, DISC_MON, CATH	-0.3 to VCC + 0.3 (Max. 30V)
	IS_P, IS_N, VFB, IFB, GPIO, ADC	-0.3 to 5.5
Output Voltage Ranges	VBUS_CTRL	-0.3 to VCC + 8 (Max. 30V)
	CC1, CC2, QCD+, QCD-, IS_P, IS_N, DISC_MON, GPIO, VDD	-0.3 to 5.5
Ambient Temperature Ranges (T _A)		-40 to 105
Operating Junction Temperature Ranges (T _J)		-40 to 105
Storage Temperature Ranges (T _{STG})		-40 to 150

5.2 Recommended Operating Conditions

Table 5-2 Recommended Operating Conditions

Parameter	MIN.	TYP.	MAX.	Unit
Supply Voltage, VCC	3.0	–	24.5	V
Supply Ground, Thermal Pad	0	0	0	

Table 5-3 Electrical Characteristics for DC Specifications

Parameter	Conditions	MIN.	TYP.	MAX.	Unit	
Input Voltage	V _{CC}	–	3.0	–	24.5	
Output Voltage	V _{DD}	V _{CC} > 5.4V	4.8	5.0	5.2	
Input Capacitance	C _{VCC}	–	–	1	–	
Output Capacitance for VDD	C _{VDD}	–	–	1	–	
Supply Current for VCC	I _{VCC}	–	–	–	20	
VCC Power Consumption in the Normal Mode	I _{VCC_A}	V _{CC} = 5V, T _A = 25°C, CC1/CC2 in Tx or Rx, no I/O sourcing current, QCD+/QCD- output voltage, HVLDO/Shunt Regulator/DAC/ LSCSA/NMOS Gate Driver/ADC on, CPU at 8 MHz	–	6	–	mA

¹⁵ Long-term exposure to absolute maximum ratings may affect device reliability, and permanent damage may occur if the operation exceeds the maximum ratings.

¹⁶ All voltage values are with respect to VSS.

¹⁷ The ratings are measured based on reference design.

Parameter	Conditions	MIN.	TYP.	MAX.	Unit
VCC Power Consumption in the Idle Mode	I_{VCC_S} $V_{CC} = 5V$, $T_A = 25^\circ C$, all blocks sleep except for CPU, CC/QCD+/QCD-, and Shunt Regulator/DAC/LSCSA/ADC on	–	2	–	mA
VCC Power Consumption in the Stop Mode	I_{VCC_DS} $V_{CC} = 5V$, $T_A = 25^\circ C$, Type-C not attached. CC/QCD+/QCD- attach function enabled for wakeup	–	450	–	μA

Table 5–4 Electrical Characteristics for I/O DC Specifications¹⁸

Parameter	Conditions	MIN.	TYP.	MAX.	Unit
Input Voltage HIGH Threshold	V_{IH}	–	$0.7 \times V_{DD}$	–	V_{DD}
Input Voltage LOW Threshold	V_{IL}	–	V_{SS}	–	$0.3 \times V_{DD}$
Output Voltage HIGH Threshold	V_{OH}	–	$V_{DD} - 0.5$	–	–
Output Voltage LOW Threshold	V_{OL}	–	–	$V_{SS} + 0.5$	–
Internal Pull-up Resistance	R_{PU} $V_{DD} = 5V$	–	50	–	k Ω
Output Source Current	I_{OH} $V_{OP} = V_{DD} - 0.5V$	–	10	–	mA
Output Sink Current	I_{OL} $V_{OP} = V_{SS} + 0.5V$	–	10	–	mA
Input Leakage Current	I_{LC}	–	–	2.0	μA
VCONN Output Voltage Threshold	V_{CONN}	–	$V_{DD} - 0.5V$	–	V
VCONN Output Current Threshold	I_{CONN}	–	–	20	mA

Table 5–5 Electrical Characteristics for ADC DC Specifications

Parameter	Conditions	MIN.	TYP.	MAX.	Unit
ADC Reference Voltage	V_{ADC_REF}	–	2.0	–	V_{DD}
ADC Clock Frequency	F_{ADCCLK}	–	–	12	MHz
ADC Sampling Rate	F_{ADCSMP} $V_{DD} = 5V$	–	–	200	kHz
ADC Offset Voltage	V_{ADC_Offset}	–	-5.0	–	5.0
No Missing Code	NMC	–	10	–	12

Table 5–6 Electrical Characteristics for Current Sense Amplifier

Parameter	Conditions	MIN.	TYP.	MAX.	Unit
CSA Accuracy	V_{CM_ACC1} 5 mV < V_{sense} < 10 mV	-15	–	15	%
	V_{CM_ACC2} 10 mV < V_{sense} < 15 mV	-10	–	10	
	V_{CM_ACC3} 15 mV < V_{sense} < 20 mV	-6.0	–	6.0	
Register-programmable Current Sense Voltage Gain	G_V +20/Step	20	–	100	V/V
Unit Gain Bandwidth	U_{BW}	–	250	–	kHz

¹⁸ The parameters below apply to P0.5, P1.4, P1.5, and P4.2.

Table 5-7 Electrical Characteristics for DISC_MON

Parameter		Conditions	MIN.	TYP.	MAX.	Unit
VBUS Discharger Sinking Current	I_{DISC_MON}	$V_{DISC_MON} = 20V$	–	16	–	mA

Table 5-8 Electrical Characteristics for VCC_DISC

Parameter		Conditions	MIN.	TYP.	MAX.	Unit
VCC Discharger Sinking Current	I_{VCC_DISC1}	$V_{CC} = 20V$	–	20	–	mA
	I_{VCC_DISC2}		–	40	–	
	I_{VCC_DISC3}		–	60	–	
	I_{VCC_DISC4}		–	80	–	
	I_{VCC_DISC5}		–	100	–	
	I_{VCC_DISC6}		–	120	–	

Table 5-9 Electrical Characteristics for QCD+/QCD- Specifications

Parameter		Conditions	MIN.	TYP.	MAX.	Unit
QCD+ Pull-down Resistance	R_{L_D+}	–	300	–	1500	k Ω
QCD- Pull-down Resistance	R_{L_D-}	–	14.25	–	24.80	
Register-programmable Output High Voltage	$V_{OH_3.0V}$	–	2.70	3.00	3.30	V
	$V_{OH_1.8V}$	–	1.62	1.80	1.98	
	$V_{OH_0.6V}$	–	0.5	0.60	0.7	
	V_{OH_APPLE}	Apple 2.4A mode	2.43	2.70	2.97	
Register-programmable Input Trip Voltage	V_{IH_D+D-}	–	1.90	2.00	2.10	
		–	0.90	1.00	1.10	
		–	0.25	0.325	0.40	
QCD+/QCD- Switch On-Resistance	R_{ON_D+D-}	–	–	20	40	Ω
Output Low Voltage	V_{OL_3V}	$R_{LOAD} = 6\text{ k}\Omega$	–	–	0.20	V
	$V_{OL_1.8V}$					
	$V_{OL_0.6V}$					

Table 5-10 Electrical Characteristics for CC1/CC2 Specifications

Parameter		Conditions	MIN.	TYP.	MAX.	Unit
Output High Voltage	V_{OH}	–	1.04	–	1.20	V
Output Low Voltage	V_{OL}	–	-0.075	–	0.075	
Rise Time/Fall Time	T_{RISE}/T_{FALL}	–	300	–	675	ns
DFP CC Termination for Default USB Power	$I_{CC_default}$	–	68	80	92	μA
DFP CC Termination for 1.5A power	$I_{CC_1.5A}$	–	165	180	194	
DFP CC Termination for 3.0A power	I_{CC_3A}	–	303	330	356	
UFP CC Termination	R_d	–	4.59	5.10	5.61	k Ω
Power Cable Termination	R_a	–	800	1000	1200	Ω

Table 5-11 Electrical Characteristics for Shunt Regulator Specifications

Parameter		Conditions	MIN.	TYP.	MAX.	Unit
Off-State CATH Current	I_{CATH_OFF}	Open-circuited CATH pin	–	–	2.0	μA
Maximum CATH Sinking Current	I_{CATH_MAX}	–	2.0	–	20	mA

Table 5–12 Electrical Characteristics for Gate Driver Specifications

Parameter		Conditions	MIN.	TYP.	MAX.	Unit
Gate to Source voltage driving external FETs	V _{GS}	–	4.5	–	8	V
Resistance when pull-down enable	R _{PD}	–	–	–	4	kΩ

5.3 AC Characteristics

Table 5–13 AC Specifications

Parameter		Conditions	MIN.	TYP.	MAX.	Unit
Main oscillator frequency	F _{CPU}	–	–	–	32	MHz
Low frequency oscillator	F _{ILRC}	–	–	16	–	kHz
Wakeup from idle mode	T _{IDLE}	–	–	180	–	μs
Wakeup from stop mode	T _{STOP}	–	–	350	–	
Power-on I/O Initialization Time	T _{POR}	–	–	6.25	–	ms

6 Mechanical Data

- 6.1 Thermal Data
- 6.2 Package Information
- 6.3 Packing Appearance and Storage Information

6.1 Thermal Data

The permissible operating temperature range for the bearing is -40°C to 105°C.

6.2 Package Information

6.2.1 Nomenclature

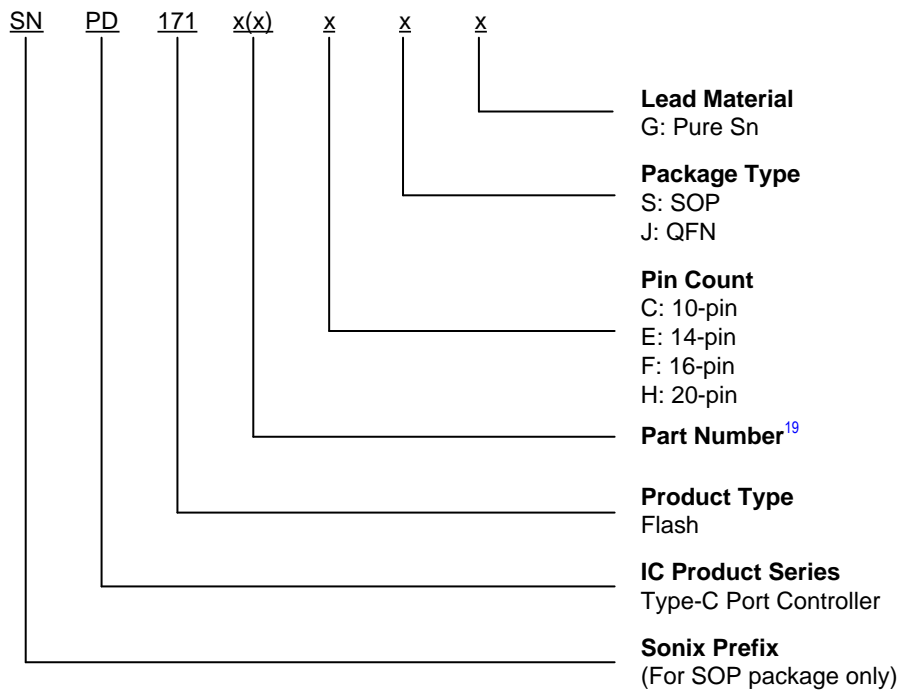

Figure 6–1 Device Nomenclature

¹⁹ For details, refer to [1.3 Selection Table](#).

6.2.2 Marking

The figure below is an example of the marking. Contents such as the product ID or symbol may vary according to different packages.

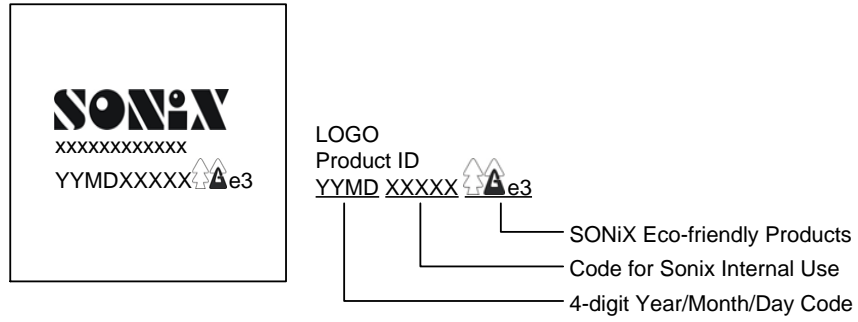
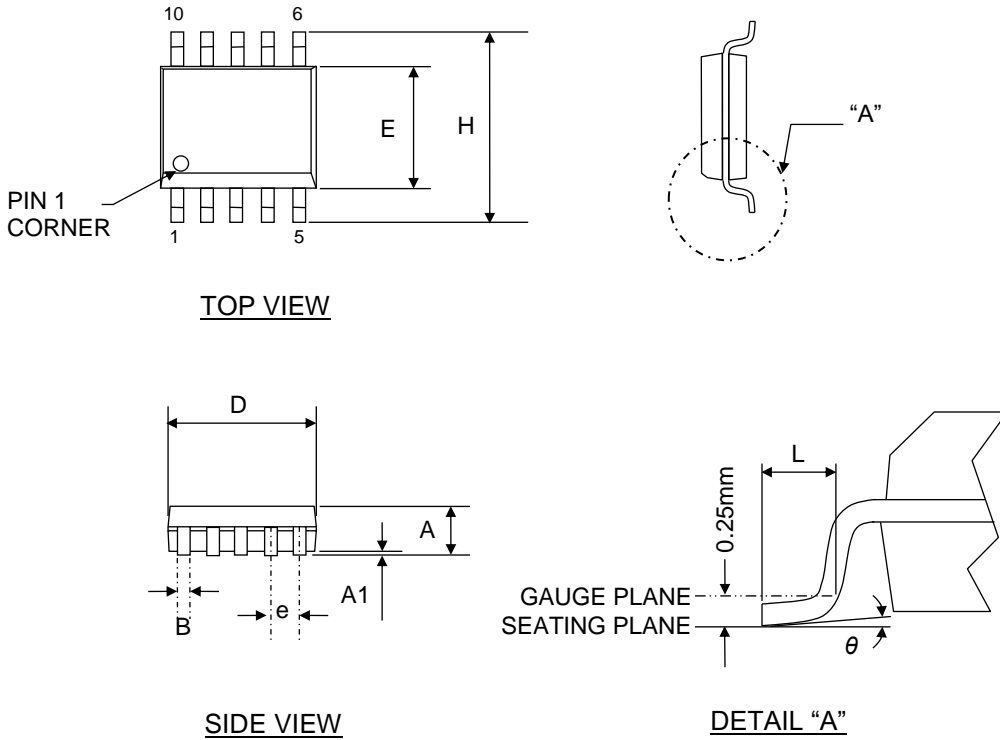

Figure 6–2 Example of Device Marking

6.2.3 Package Dimensions

I. SOP10L (150 MIL)



Symbols	Dimension in mm ²⁰			Dimension in inch		
	MIN.	NOM.	MAX.	MIN.	NOM.	MAX.
A	–	–	1.75	–	–	0.069
A1	0.10	–	0.25	0.004	–	0.010
B	0.30	–	0.45	0.012	–	0.018
D	4.90 BSC			0.193 BSC		
E	3.90 BSC			0.153 BSC		
e	1.00 BSC			0.039 BSC		
H	6.00 BSC			0.236 BSC		
L	0.40	–	1.27	0.016	–	0.050
θ	0°	–	8°	0°	–	8°

²⁰ Controlling dimension: millimeter (mm)

II. SOP14L (150 MIL)

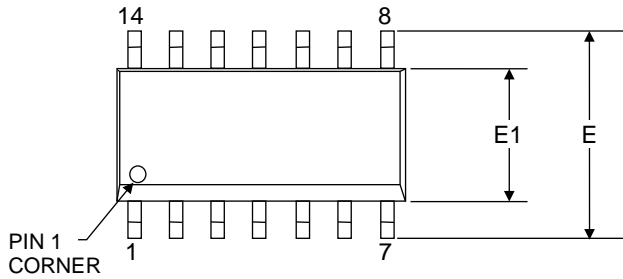

TOP VIEW

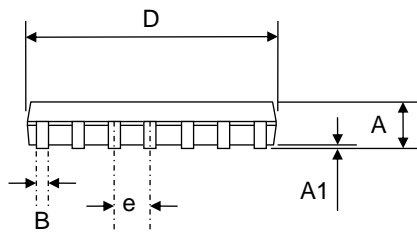
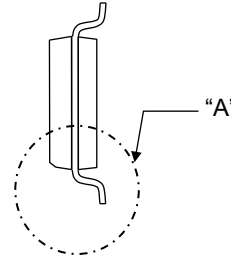

SIDE VIEW

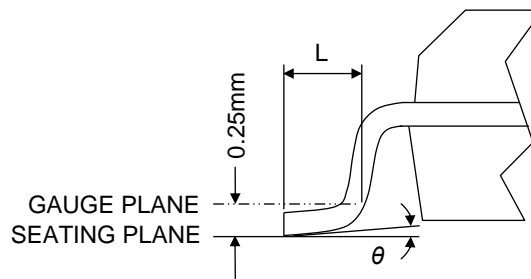

DETAIL "A"

Symbols	Dimension in mm ²¹			Dimension in inch		
	MIN.	NOM.	MAX.	MIN.	NOM.	MAX.
A	–	–	1.75	–	–	0.069
A1	0.05	–	0.25	0.002	–	0.010
B	0.31	–	0.51	0.012	–	0.020
D	8.65 BSC			0.340 BSC		
E1	3.90 BSC			0.154 BSC		
e	1.27 BSC			0.050 BSC		
E	6.00 BSC			0.236 BSC		
L	0.40	–	1.27	0.015	–	0.050
θ	0°	–	8°	0°	–	8°

²¹ Controlling dimension: millimeter (mm)

III. QFN16L (4 x 4 x 0.8 mm, Pitch: 0.65 mm)

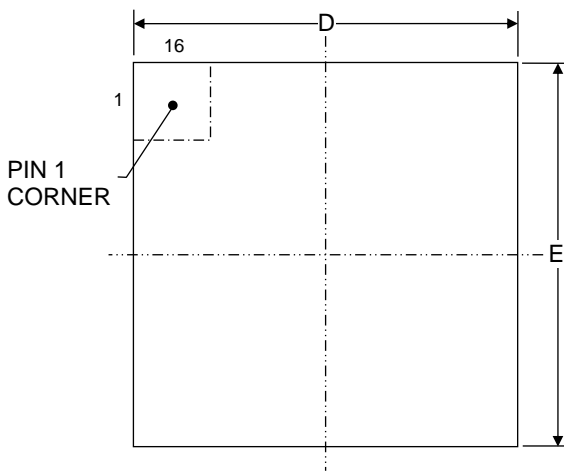

TOP VIEW

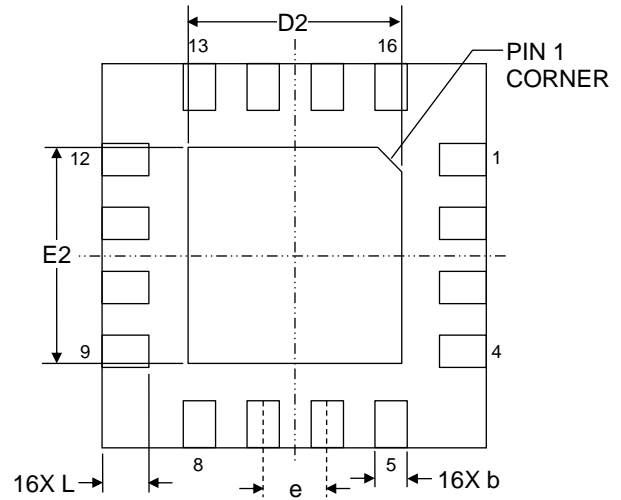

BOTTOM VIEW
VIEW M-M

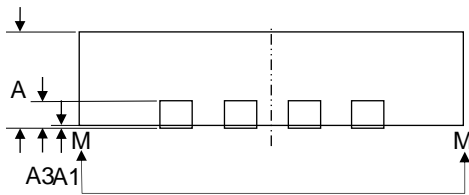

SIDE VIEW

Symbols	Dimension in mm ²²			Dimension in inch		
	MIN.	NOM.	MAX.	MIN.	NOM.	MAX.
A	0.70	0.80	0.90	0.028	0.031	0.035
A1	0.00	0.02	0.05	0.000	0.001	0.002
A3	0.20 REF			0.008 REF		
b	0.25	0.30	0.35	0.010	0.011	0.012
D	4.00 BSC			0.157 BSC		
E	4.00 BSC			0.157 BSC		
e	0.65 BSC			0.025 BSC		
D2	2.00	2.40	2.80	0.078	0.094	0.110
E2	2.00	2.40	2.80	0.078	0.094	0.110
L	0.30	0.40	0.50	0.011	0.015	0.019

²² Controlling dimension: millimeter (mm)

IV. QFN20L (4 x 4 x 0.8 mm, Pitch: 0.5 mm)

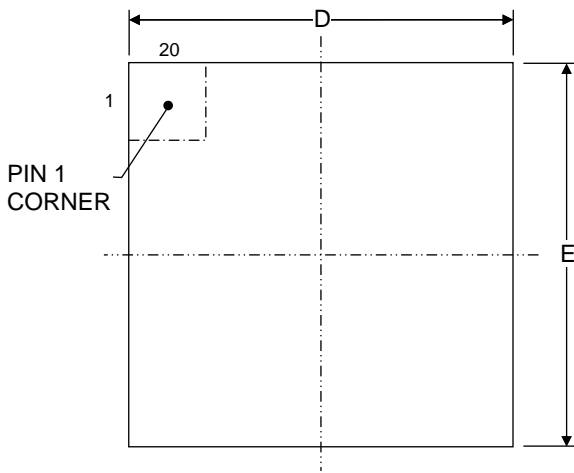

TOP VIEW

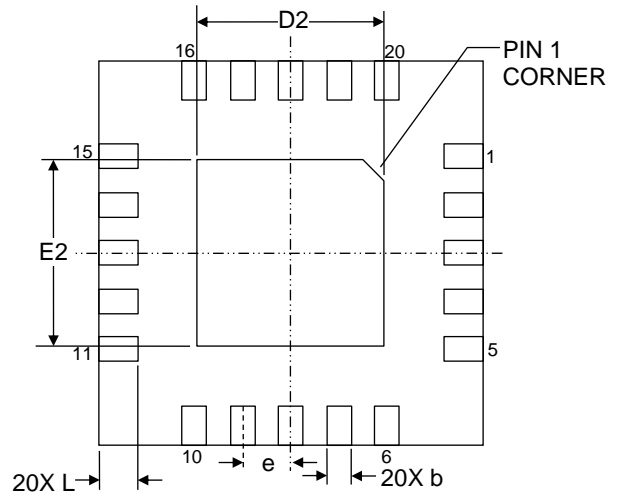

BOTTOM VIEW
VIEW M-M

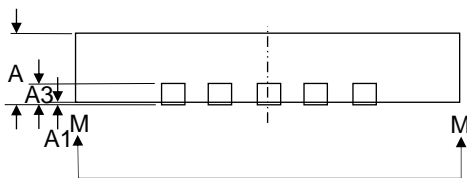

SIDE VIEW

Symbols	Dimension in mm ²³			Dimension in inch		
	MIN.	NOM.	MAX.	MIN.	NOM.	MAX.
A	0.70	0.80	0.90	0.028	0.031	0.035
A1	0.00	0.02	0.05	0.000	0.001	0.002
A3	0.20 REF			0.008 REF		
b	0.18	0.24	0.30	0.007	0.010	0.012
D	4.00 BSC			0.157 BSC		
E	4.00 BSC			0.157 BSC		
e	0.50 BSC			0.020 BSC		
D2	1.90	2.30	2.70	0.075	0.090	0.106
E2	1.90	2.30	2.70	0.075	0.090	0.106
L	0.30	0.40	0.50	0.012	0.016	0.020

²³ Controlling dimension: millimeter (mm)

6.3 Packing Appearance and Storage Information

6.3.1 Packing Quantity Information

Table 6-1 Packing Quantity Information

Type	Pin Count	Carry Type	Package Size	IC Q'ty per Tube or Tray or Reel	Tube or Tray or Reel Q'ty per Inner Box	Total Q'ty in One Inner Box	Inner Box Q'ty per Carton	IC Q'ty per Carton
SOP	10	Tube	150 MIL	100	100	10000	6	60000
SOP	14	Tube	150 MIL	58	100	5800	6	34800
QFN	16	Tray	4 x 4	490	10	4900	6	29400
QFN	16	Tape & Reel	4 x 4	2500	1	2500	10	25000
QFN	20	Tray	4 x 4	490	10	4900	6	29400
QFN	20	Tape & Reel	4 x 4	2500	1	2500	10	25000

6.3.2 Packing Box/Carton Dimension

Table 6-2 Inner Box/Carton Dimension

Inner Box/Carton	Carry Type	Dimension in mm
Inner Box	Tray	358 x 159 x 88
	Tube	610 x 170 x 100
	Tape & Reel	355 x 340 x 50
Carton	Tray	555 x 435 x 280
	Tube	630 x 360 x 345
	Tape & Reel	560 x 360 x 385

6.3.3 Temperature and Humidity Environmental Control Requirements in Storage

Table 6-3 Store Condition

Control Requirement	Specification
Temp. (°C)	24 ± 6
Humid. (%RH)	60 ± 20

6.3.4 Shelf-life

1. The shelf life for unopened vacuum pack products is four years after the date on the label.
2. Once the packaging is opened the product should be conducted SMT process within 168 hours and environmental control is under ≤ 30°C / 60 %RH.
3. If the product has been exposed to the room environment for more than 168 hours, it should be baked in an oven at 125°C for 10 hours and vacuum packed.

TERMS AND CONDITIONS²⁴

1. **Content:** Sonix Technology Co. Ltd. ("Sonix") provides this information as a convenient reference solely for its customers. While Sonix takes care to prepare this information, it may contain typographical errors or outdated technical information as Sonix continues to update its products with enhancements and improvements. Customers should inquire of the appropriate Sonix representative to obtain the latest relevant information concerning specific Sonix product(s) before placing orders. All Sonix's products are sold subject to Sonix's terms and conditions of sale that are supplied at the time of acceptance by Sonix.

2. **No Warranty:** The information contained in this document is presented only as a reference for Sonix's customers. Sonix does not warrant or represent that any license, either express or implied, is granted by this document relating to any combination, machine, or process in which Sonix's products are used (or to be used). Information in this document regarding third-party products is not a license for use of such products, or a warranty or endorsement thereof. No license to any intellectual property is granted by this document, whether express or implied, by estoppel or otherwise. Absent a written signed agreement or except as provided in the relevant terms and conditions of sale for a specific product, and to the maximum extent allowable by law, SONIX and its third-party suppliers (1) ALL SONIX PRODUCTS ARE SOLD "AS-IS, WHERE-IS," (2) ASSUME NO LIABILITY WHATSOEVER, INCLUDING WITHOUT LIMITATION, INDIRECT, CONSEQUENTIAL, SPECIAL, OR INCIDENTAL DAMAGES OR LOSS, INCLUDING WITHOUT LIMITATION, LOSS OF PROFITS, LOSS OF OPPORTUNITIES, BUSINESS INTERRUPTION, AND LOSS OF DATA, and (3) DISCLAIM ANY AND ALL EXPRESS OR IMPLIED WARRANTIES AND CONDITIONS RELATED TO SALE, USE OF PRODUCT, OR INFORMATION, INCLUDING WARRANTIES OR CONDITIONS OF MERCHANTABILITY, FITNESS FOR A PARTICULAR PURPOSE, ACCURACY OF INFORMATION, OR NONINFRINGEMENT.

3. **Customers' Use:** While from time to time Sonix may assist customers with its products, Sonix undertakes no responsibility or liability for its customer's own design, application and use of Sonix's products, including but not limited to: (a) determining the appropriateness of the use of Sonix products in the desired design or application; (b) evaluating and determining the applicability of any information contained in this document, or in charts, diagrams, programs, algorithms, sample application circuits or other referenced documents provided by Sonix; and (c) validating all operating parameters for such designs and applications.

4. **Improper & Unintended Use:** SONIX'S PRODUCTS ARE NOT INTENDED NOR WARRANTED FOR USE IN OR FOR (1) EQUIPMENTS OR SYSTEMS THAT REQUIRE EXTRAORDINARILY HIGH LEVELS OF QUALITY OR RELIABILITY, OR A MALFUNCTION OR FAILURE OF WHICH MAY CAUSE LOSS OF HUMAN LIFE, BODILY INJURY, SERIOUS PROPERTY DAMAGE, OR SERIOUS PUBLIC IMPACT or (2) ANY PRODUCTS OR SYSTEMS WHOSE MANUFACTURE, USE OR SALE IS PROHIBITED UNDER ANY APPLICABLE LAW OR REGULATIONS ("Unintended Use"). Unintended Use includes, without limitation, equipment used in nuclear facilities, equipment used in the military or aerospace industry, medical equipment, equipment used for automobiles, trains, ships, and other transportation, traffic signaling equipment, equipment used to control combustions or explosions, safety devices, elevators, and escalators, devices related to electric power, and equipment used in finance-related fields. Users acknowledge and agree that any Unintended Use of Sonix products is solely at the user's own risk and without recourse to Sonix or any of its suppliers, agents or representatives in connection therewith.

²⁴ The information contained in this document is the property of Sonix, and none of it may be used, reproduced or distributed without the express written permission by Sonix.

Sonix Technology Co., Ltd.

Headquarter

10F-1, No. 36, Taiyuan Street,
Zhubei City, Hsinchu County, Taiwan
Tel: +886-3-5600-888
Fax: +886-3-5600-889

<http://www.sonix.com.tw/masterpage-en>

Japan Office

Kobayashi Bldg. 2F,
4-8-27 Kudanminami, Chiyodaku,
Tokyo 102-0074, Japan
Tel: +81-3-6272-6070
Fax: +81-3-6272-6165

jpsales@sonix.com.tw

Shenzhen Office

26F, Zhongliang Ziyun Building,
Xin'an 2nd Road, Bao'an District,
Shenzhen City, China
Tel: +86-755-2671-9666
Fax: +86-755-2671-9786

mkt@sonix.com.tw | sales@sonix.com.tw

United States Representative

Tim Lightbody
Tel: +1-714-330-9877
usa@sonix.com.tw

Taipei Office

15F-2, No. 171, Songde Road,
Xinyi District, Taipei City, Taiwan
Tel: +886-2-2759-1980
Fax: +886-2-2759-8180

mkt@sonix.com.tw | sales@sonix.com.tw

Hong Kong Office

Unit 2603, 26F CCT Telecom Building,
No. 11, Wo Shing Street, Fo Tan,
New Territories, Hong Kong
Tel: +852-2723-8086
Fax: +852-2723-9179

hk@sonix.com.tw

Chengdu Office

8F, B6 Building, Tianfu Software Park,
No. 99, Tianhua 1st Road, Hi-tech Zone,
Chengdu City, China
Tel: +86-28-8533-1818
Fax: +86-28-8533-1816

mkt@sonix.com.tw | sales@sonix.com.tw